

LEISTER Forte S3 □ Hot Air Blower



Please read operating instructions carefully before use and keep for further reference.

APPLICATION

- **Shrinking** of shrink-hoods and films used in packaging goods of all types.
- **Drying** of water-damp surfaces.
- **Heating-up** for forming, bending and sealing of thermoplastic semi-finished materials.
- **Defrosting** of frozen water pipes.
- **Activating** single or multi-component adhesives.
- **Removing** old shellac, oil, resin paints and underseals on vehicles.





WARNING



Danger! Unplug the tool before opening it, as live components and connections are exposed.



Incorrect use of hot air tools can present a **fire and explosion hazard**, particularly in the proximity of flammable materials and explosive gases.



CAUTION



The **rated voltage** stated on the tool must correspond with the mains voltage.



For personal protection, we strongly recommend the tool to be connected to an **RCCB** (Residual Current Circuit Breaker) before using it on construction sites.



Do not touch the element housing and nozzle when hot as they can cause **burns**. Do not point the hot air flow in the direction of people or animals.



The tool must be operated **under supervision**. Heat can ignite flammable materials which are not in view.



Protect the tool **from damp and wet**.

Approval Marks



This tool is **CCA** certificated (CENELEC Certification Agreement).

TECHNICAL DATA

Electrical safety: double insulated

Voltage	V~	3x230, 3x400, 3x440, for 50/60 Hz
Capacity	kW	10 10 10
Temperature	°C	650
Air flow	l/min.	1000
Air pressure	mbar	12
Noise level	dB (A)	76
Weight	kg	3.4 without cable, 5.2 with 10m cable
Size	mm	390 x 132 x 215

Mains voltage cannot be switched over

Description of tool

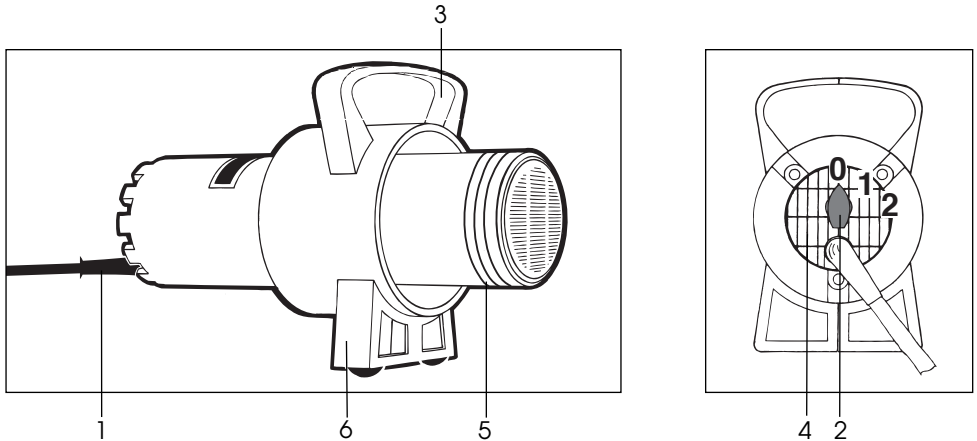

- | | |
|--|--|
| <ol style="list-style-type: none"> 1. Cable to mains 2. Switch: stage 0 = off
stage 1 = cold air
stage 2 = hot air | <ol style="list-style-type: none"> 3. Handle 4. Air intake with grille 5. element housing 6. Stand |
|--|--|

Operation

- Connect tool to the mains.
- Set **Switch (2)** to stage 2 and allow to warm up for about 1 min.
- Rest tool on heat resistant surface. Make sure no objects or obstacles stand in the way of the air outlet because of the fire hazard.
- The Leister Company, as well as the Service Centres, offer free training courses in all areas of application (see page 1).
- After completing the work, **switch (2)** to stage and allow the tool to cool down.

MAINTENANCE

- The tool's **air intake grille(4)** should be cleaned with a fine brush.

SERVICE AND REPAIRS

- The carbon brushes of the welding tool's motor should be checked after about 1600 hours running time by your Service Centre.
- Repairs should only be carried out by authorised **LEISTER Service Centres**. They guarantee a correct and reliable **repair service within 24 hours** using original spare parts in accordance with the circuit diagrams and spare parts lists.

GUARANTEE AND LIABILITY

- Guarantee and liability are in accordance with the guarantee certificate as well as with the currently valid general business and sales conditions.
- LEISTER Process Technologies rejects any guarantee claims for tools which are not in their original condition. The tools must never be altered or changed.

Technical data and specifications are subject to change without prior notice.

Your authorized Service Centre is: